

## ARCHITECTURAL CONTROL COMMITTEE FOR EXISTING STRUCTURES



### GREENWOOD VILLAGE



### SPECIFICATIONS FOR SINGLE FAMILY HOME MAILBOXES

#### GENERAL CRITERIA:

Mailboxes must meet U.S. Postal requirements and must include a separate opening for newspapers. Commercial newspaper boxes (such as the plastic boxes with the newspaper's logo on the side, i.e., Plain Dealer, Akron Beacon Journal, etc.), whether attached or separately mounted, are prohibited.

Basic unit shall consist of the standard metal Post Office approved rural mailbox enclosed in a wooden structure, which provides a separate space for newspapers or flyers. The overall size should be **NO MORE THAN TWICE THAT OF THE BASIC UNIT**, and maintain a plain rectangular shape – with the permissible addition of a gable roof. A wooden mailbox the same size and design as the Clubhouse mailbox is also permissible.

It is also acceptable to use a Rubbermaid Step 2 mailbox. Only the MailMaster Plus model is permissible, with one (1) space for newspapers & flyers. Color to coordinate with home. Tan, green, or black only.

Mailboxes which comply with the above requirements do not require ACCES Approval. All other mailboxes require ACCES approval.

#### COLORS:

Conservative earth tone colors should be used, preferably matching the house, with one contrasting trim color allowed, if desired. Other than house or unit numbers, no other design or decoration is permitted.

#### HOUSE NUMBERS:

House numbers must be displayed on the right-hand side of the mailbox or enclosure (when you are facing the mailbox). Displaying the numbers on both sides of the mailbox is also highly recommended. They should also be displayed on the residence for safety considerations.

#### MOUNTING:

A single metal or wood post, protruding **NO MORE THAN 6"** (six inches) above the top of the mailbox, shall support the structure.

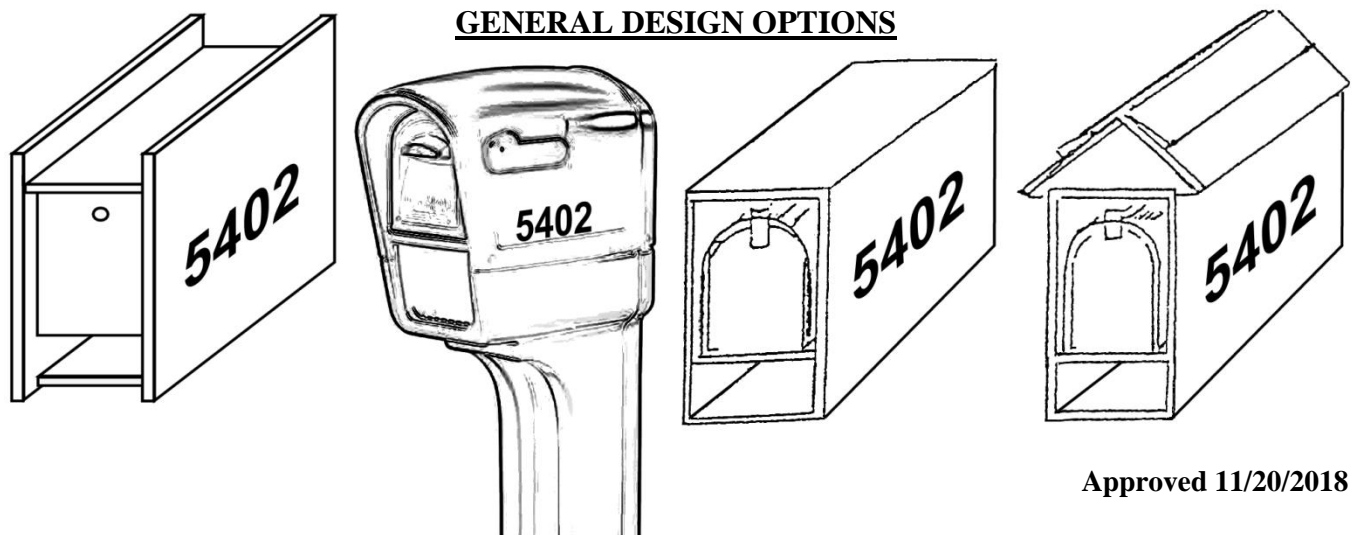

Approved 11/20/2018